



THE AIR HEATER OF CHOICE  
FOR TRUCKS





## ULTRA-QUIET AIR HEATER WITH ADVANCED DRIVER CONTROL PANEL

Proheat Air is the new standard for heavy-duty truck air heaters, quietly delivering constant and reliable heat in cold weather environments. Available in 2 and 4 kW models, its high-efficiency design reduces overall vehicle emissions and engine wear by eliminating the need to idle the engine to heat the sleeper cab. Proheat Air saves fuel costs for fleets and operators while helping drivers comply with local idling restrictions. A digital remote panel provides comprehensive and precise control of Proheat Air from anywhere inside the truck cab.



### PRECISION HEATER CONTROL

The Proheat Air truck kit includes a digital Driver Control Panel (DCP) that makes set-up and operation of the heater quick and easy. The DCP features a large, backlit LCD screen that displays at-a-glance heater status, temperature, time, and power level.

A surface-mount design means it can be installed inside the cab wherever it's most convenient. An intuitive five button design ensures drivers can easily program and control the heater to suit their needs.

### MAXIMUM DRIVER COMFORT AND CHOICE

Using the advanced DCP, truckers have several options as to how and when Proheat Air heats their truck. Timers allow drivers to start Proheat Air at a specific time so the truck is warm when they arrive. The DCP also allows drivers to specify an ambient temperature inside the cab, triggering the heater to cycle on and off automatically to maintain the correct temperature, just like at home. Alternatively, a fixed power level can be selected for the heater to run for a specific length of time. In warm weather the heater's fan can circulate air inside the cab to help with ventilation.

### A COMPLETE TRUCK HEATING SOLUTION

Proheat Air includes all the common components necessary for a typical installation. This includes the cabling and fittings to mount the heater in a safe location and connect it to the truck's fuel tank.

In addition to temperature sensors built into both the heater and the DCP, an optional third sensor can be added to the system. This extra sensor can be mounted outside the truck cab for example, or inside a trailer to monitor temperature in the cargo area. Optional mounting hardware is also available to make attaching the heater to some truck sleeper floors easier.

### DESIGNED FOR HEAVY DUTY TRUCKS

Proheat Air is designed for safe use on heavy duty trucks. Its low amperage draw ensures the starting battery is not overdrawn so that the truck will start when needed. The heater is also designed to run on common diesel fuels including B5 bio-diesel.

The 4000 watt output of a Proheat Air A4 is powerful enough to be used as a cargo heater. The A4 can be installed in the cargo area to protect temperature-sensitive cargo from cold weather damage.

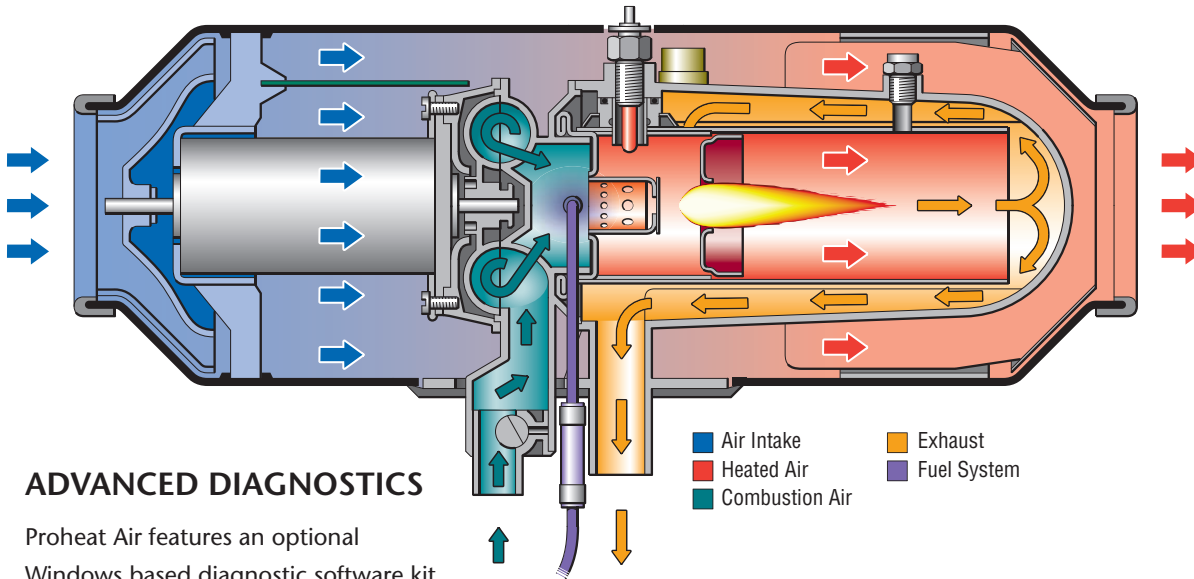

## ADVANCED DIAGNOSTICS

Proheat Air features an optional Windows based diagnostic software kit to help technicians maintain performance. Monitoring the heater is easy via the included interface cable which connects to any USB port. Not only can technicians test and monitor the heater in real-time, but they can download historical data from the heater including run time and status messages. This diagnostic tool provides a wealth of information for technicians to maintain peak heater performance.



## CUT OPERATING COSTS & EMISSIONS

By installing Proheat Air, fleets and operators can save thousands of dollars each year by eliminating the need to idle the vehicle's engine as a source of heat for driver comfort. Engine idling puts unnecessary hours on the engine, increasing engine wear and overall vehicle emissions. Prohibiting idling is also quickly becoming the focus of local and federal law makers, as well as a target for local law enforcement.

Proheat Air uses a fraction of the fuel a truck engine uses to idle while still generating a quiet, constant flow of heat that drivers can adjust as desired.

How many hours do your trucks idle for cab comfort heating in a typical year? Since Proheat Air burns 95% less fuel than a truck engine, trucks that idle unnecessarily for hundreds of hours will pay for a Proheat Air in a single winter season.

Table 1 provides sample calculations for fuel and cost savings realized by installing Proheat Air.

|  |                   |                   |
|--|-------------------|-------------------|
| 1 Fuel Used per Hour Idling Truck Engine                                     | 1.0 gallons       | 3.8 litres        |
| 2 Fuel Used per Hour Using Proheat Air (A2)                                  | 0.03 gallons      | 0.1 litres        |
| 3 Fuel Savings per Hour Using Proheat Air (A2)                               | 0.97 gallons      | 3.7 litres        |
| 4 Heat Required per Year   | 20 weeks          |                   |
| 5 Heat Required per Week   | 5 days            |                   |
| 6 Time per Rest Period   | 8 hours           |                   |
| 7 Total Time per Year Requiring Heat (Line 4 x Line 5 x Line 6)              | 800 hours         |                   |
| 8 Yearly Total of Fuel Saved Using Proheat Air (A2) (Line 3 x Line 7)        | 776 gallons       | 2960 litres       |
| 9 Price of Fuel  | \$2.80 per gallon | \$0.735 per litre |
| 10 Yearly Total of Fuel Costs Saved Using Proheat Air (A2) (Line 8 x Line 9) | \$2,173           | \$2,173           |

**TABLE 1** – Sample Fuel Savings. *Additional savings will be realized from reduced engine wear and maintenance.*

## AT A GLANCE

### HEATER FEATURES

- 2kW (A2) and 4kW (A4) models available
- Built-in temperature sensor for safety and control
- Ultra-quiet operation
- Optional diagnostic software kit available

### DIGITAL CONTROL PANEL FEATURES

- Backlit LCD display
- Easy set-up and control
- At-a-glance display of heater status (Temperature, time, and power)
- Stores multiple timer events
- Surface mount design

### TWO YEAR WARRANTY

*Proheat Air is backed by a full two year parts and labor warranty and is supported by a nationwide network of Authorized Proheat Dealers.*

## SPECIFICATIONS

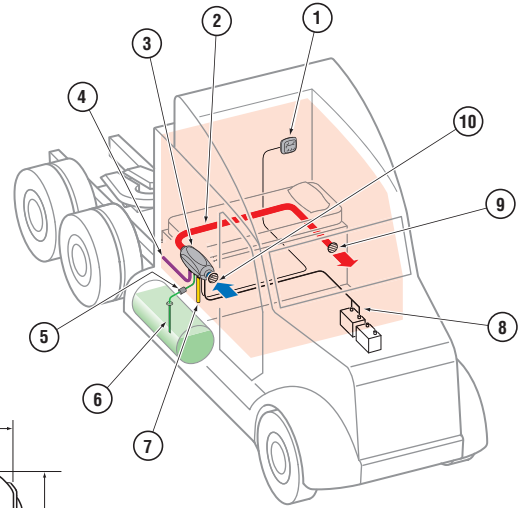
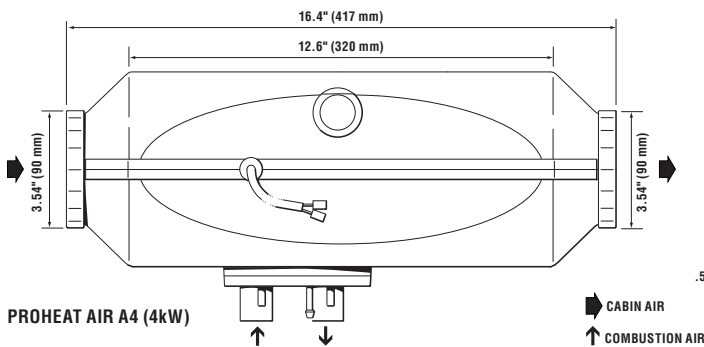
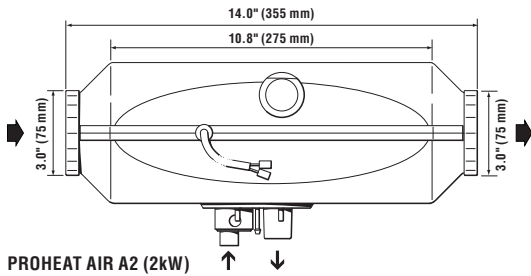

- 1 Driver Control Panel (DCP)
- 2 Ducting
- 3 Heater
- 4 Exhaust
- 5 Electric Fuel Pump
- 6 Fuel Pick-Up
- 7 Combustion Air Intake
- 8 Electrical Connection
- 9 Heated Air
- 10 Air Intake

## ABOUT TELEFLEX POWER SYSTEMS

Teleflex Power Systems is a global leader in advanced auxiliary heaters, auxiliary power systems, and alternative fuel components and systems for engines. Our customers include after-market vehicle dealers and service organizations as well as manufacturers of transport trucks, locomotives, buses, automobiles, forklifts, off-highway, and military vehicles — all backed by the resources of our parent company Teleflex Inc. (NYSE: TFX), a global diversified industrial leader with annual revenues of more than \$2.5 billion.

Teleflex Inc. designs, manufactures, and distributes quality engineered products and services for the commercial, medical, and aerospace markets worldwide. Teleflex Inc. employs more than 19,000 people worldwide.

| MODEL                              | A2 (12V)   | A2 (24V)                       | A4 (12V)                                     | A4 (24V)                        |
|------------------------------------|--|--------------------------------|--|---------------------------------|
| <b>RATING</b>                      | 2 kW (6,800 BTU)   | 2 kW (6,800 BTU)               | 4 kW (13,600 BTU)                            | 4 kW (13,600 BTU)               |
| <b>OPERATING VOLTAGE RANGE</b>     | 10.5 – 15 VDC  | 21 – 30 VDC                    | 10.5 – 15 VDC                                | 21 – 30 VDC                     |
| <b>POWER CONSUMPTION</b>           |  |                                |  |                                 |
| Stand-By                           | 0.4 W  | 0.4 W                          | 0.4 W  | 0.4 W                           |
| Ignition                           | 130 W  | 130 W                          | 145 W  | 145 W                           |
| Maximum Heat                       | 25 W   | 25 W                           | 60 W   | 60 W                            |
| <b>FUEL CONSUMPTION</b>            | .03-.06 gal/hr (0.1-0.22 L/hr)   | .03-.06 gal/hr (0.1-0.22 L/hr) | .06-.12 gal/hr (0.21-0.46 L/hr)              | .06-.12 gal/hr (0.21-0.46 L/hr) |
| <b>FUEL TYPES</b>                  | ULSD, Diesel #1, Diesel #2, Arctic, B5 Bio-diesel  |                                |  |                                 |
| <b>OPERATING TEMPERATURE RANGE</b> | Ventilation Mode: - 40°F to 149°F (- 40°C to 65°C)<br>Heating Mode: - 40°F to 104°F (- 40°C to 40°C) |                                |  |                                 |
| <b>AIRFLOW (Maximum)</b>           | 41 CFM (70 m³/hr)  |                                | 65 CFM (110 m³/hr)                           |                                 |
| <b>WEIGHT</b>                      | 7.7 lb (3.5 kg)  | 7.7 lb (3.5 kg)                | 11.2 lb (5.1 kg)                             | 11.2 lb (5.1 kg)                |
| <b>DIMENSIONS (L x W x H)</b>      | 14 x 4.75 x 6.14 inches (355 x 120 x 156 mm)   |                                | 16.4 x 6.1 x 7.4 inches (417 x 154 x 189 mm) |                                 |
| <b>WARRANTY</b>                    | Driver Control Panel: 3.0 x 3.3 x 0.7 inches (75 x 85 x 17 mm)<br>Two years parts and labor          |                                |  |                                 |

Dealer:

Please Note: Specifications are subject to change without notice. Teleflex and Proheat are registered trademarks of Teleflex Inc. and its subsidiary companies.